



Batterij Kettingtaket / Battery Chain Hoist

Eigenschappen

- » Eenvoudig te installeren voor snel gebruik.
- » Eenvoudig te bedienen en te transporteren door zijn lage gewicht en draagbare koffer.
- » Ideaal voor toepassingen zonder stroomvoorziening.
- » Batterijvermogen: 25min bij maximale belasting.
- » Geleverd met reserve batterij en oplader.
- » Wartel lasthaak met veiligheidsklep.
- » Geleverd klaar voor gebruik met bedieningsschakelaar en kettingbak.
- » Voldoet aan de Machinerichtlijn 2006/42/EG. Geleverd met testcertificaat, CE-conformiteitsverklaring en gebruiksaanwijzing.

Features

- » Fast installation.
- » Easy handling and high transportability due to low weight and carrying case.
- » Ideal for applications without power supply.
- » Battery power: 25min at maximum load.
- » Delivered with spare battery and charger.
- » Swivel load hook with safety latch.
- » Supplied ready to use with control switch and chain container.
- » Complies with the Machinery Directive 2006/42/EC. Supplied with test certificate, CE declaration of conformity and operating instructions.



CZ.0.DBH

NEW
2022NEW
2022

Specificaties / Specifications							
Artikelnummer	Capaciteit	Hijshoogte	Hijssnelheid	Hijsketting	Parten	Energieverbruik	Netto gewicht
Article code	Capacity	Hoisting height	Lifting speed	Load chain	Chain falls	Power output	Net weight
	ton	m	m/min	Øxmm		kW	kg
CZ.0.DBH.250.10	0.25	10	4.5	4 x 12	1	-	12
CZ.0.DBH.500.05	0.5	5	2.2	4 x 12	2	-	13.5

Specificaties / Specifications	
Voltage / Operating voltage	18V (5.0Ah 90Wh) oplaadbare li-ion batterij / 18V (5.0Ah 90Wh) rechargeable li-ion battery
Hijssnelheid / Lifting speed	Variabele snelheid (tijdens zakken) / Variable speed (when lowering)
Hijsketting / Load chain	Gegalvaniseerde lastketting volgens EN 818-7 / Galvanized load chain according to EN 818-7
Stuurkabel / Control cable	Standaard ≈3 meter / Standard ≈3 meter
Stroomkabel / Power cable	-
Behuizing bescherming / Housing protection	IP 54
Besturing bescherming / Control protection	IP 50
Classificatie / Classification	M4/1Am (ISO/FEM)
Inschakelduur / Starts per uur / Duty cycle / Starts per hour	30% / 180
Isolatieklasse / Insulation class	F
Bedrijfstemperatuur / Operating temperature	-10°C - +40°C
Ladingtype / Load type	Alleen voor goederen, niet geschikt om personen te hijsen / Goods, may not be used to lift people

Beveiliging / Protection	
Schakelaar / Control switch	Schakelaar met noodstop / Pendant control switch with emergency stop button
Overlastbeveiliging / Overload protection	Extern instelbare slipkoppeling en digitale beveiliging / Externally adjustable slip clutch and digital protection
Rem / Brake	Mechanische rem / Mechanical brake
Eindschakelaar / Limit switch	Elektromagnetische hoogste eindschakelaar, laagste positie beveiligd door slipkoppeling / Electromagnetic upper limit switch, lower limit protected through slip clutch
Thermische bescherming / Thermal protection	Geen bescherming / No protection



Batterij Kettingtakel / Battery Chain Hoist

Draagkoffer / Carrying case		
Capaciteit	Totale gewicht *	Afmetingen
Capacity	Total weight *	Dimensions
ton	kg	mm
0.25	20.3	640 x 420 x 280
0.5	23.2	

* inclusief alle accessoires en standaard hijshoogte / including all accessories and standard hoisting height

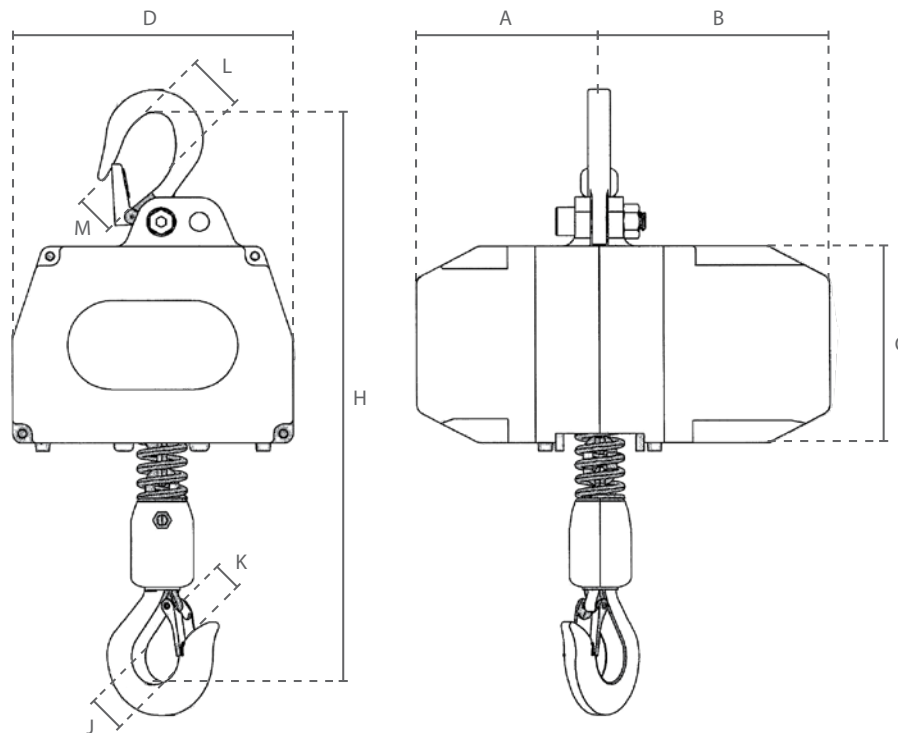

Artikelnummer	Afmetingen / Dimensions									
	A	B	C	D	H	J	K	L	M	
CZ.0.DBH.250	114	144	122	173	355	29	19	27	20	
CZ.0.DBH.500	114	144	122	173	375	29	19	27	20	